

16 PVC Foam Tape, 3 mm x 6 mm RS Pro 205-0805

15	CWC-ST0004-P01_RTV ASSEMBLY RULER	1
14	CWC-ST0003-P01_LTV ASSEMBLY RULER	1
13	CWC-PR0001-P04_SNAP HOLDER	3
12	CWC-SP0008-P01_CAMSUPPORT SHORT	2
11	CWC-SP0011-P01_CORNERCLIP FEMALE	16
10	CWC-SP0010-P01_CORNERCLIP MALE	20
9	CWC-SP0012-P01_ITEM PLATFORMCLIP RAIL ADAPTER	14
8	NUTSTEIN M5 PROFIL 5 ITEM 0.0.425.11	59
7	BN616-1208187 M5X8 SCREW HEX COUNTERSUNK	59
6	AUTOMATIK VERBINDUNGSSATZ PROFIL 5 ITEM 0.0.437.46	8
5	ABDECKKAPPE PROFIL 5 ITEM 0.0.370.09	8
4	CWC-ST1005-P04_ITEM FRAME OUTSIDE HEIGHT	4
3	CWC-ST1004-P04_ITEM FRAME OUTSIDE WIDTH	4
2	CWC-ST1003-P04_ITEM FRAME OUTSIDE LENGTH	4
1	CWC-ST0003-P02_FISHTANK	1
PC NO	PART NAME	QTY

Necessary Tools:

- Rubber Mallet
- Allen key set

2x

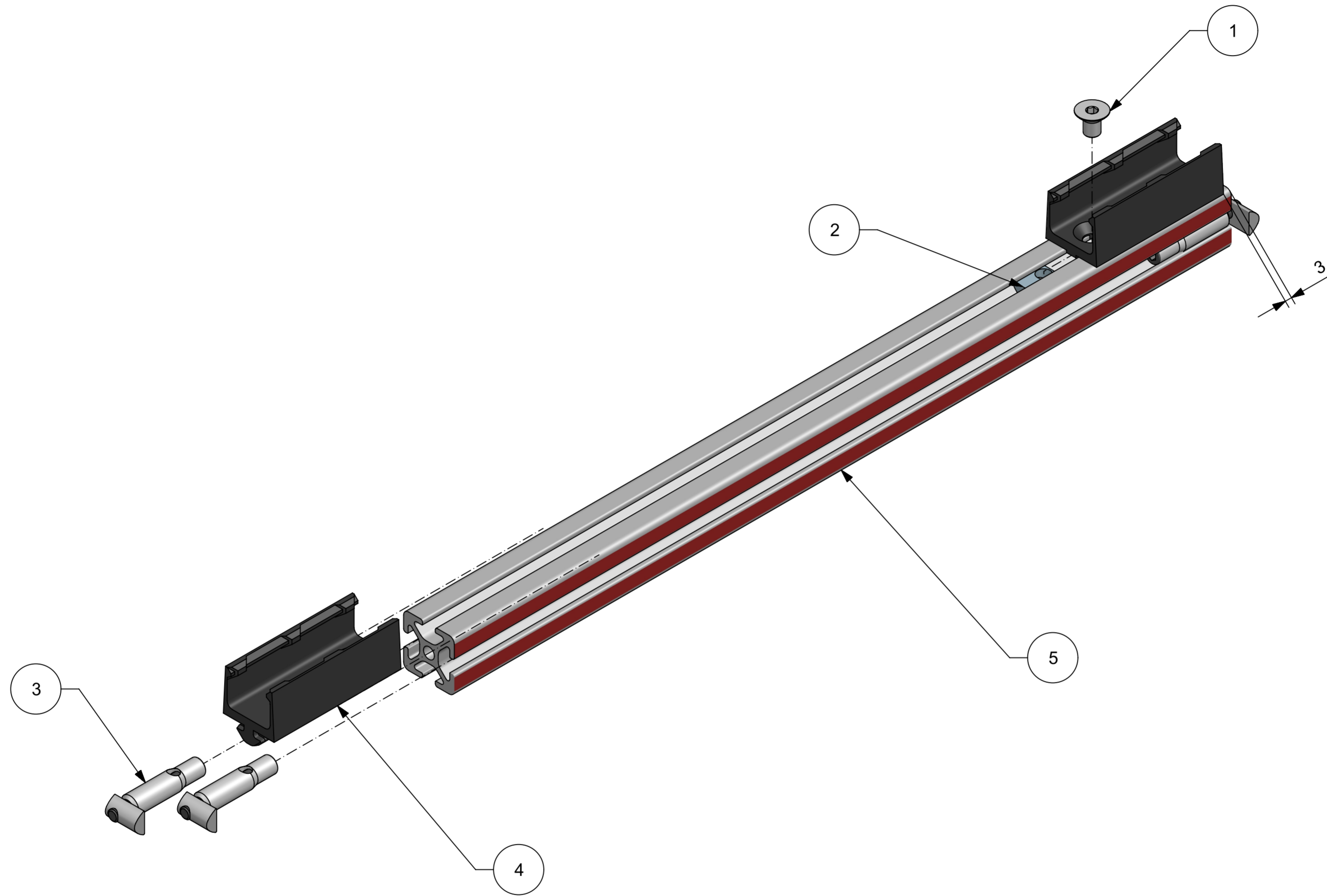

5	CWC-ST1004-P04_ITEM FRAME OUTSIDE WIDTH	1
4	CWC-SP0011-P01_CORNERCLIP FEMALE	2
3	AUTOMATIK VERBINDUNGSSATZ PROFIL 5 ITEM 0.0.437.46	4
2	NUTSTEIN M5 PROFIL 5 ITEM 0.0.425.11	2
1	BN616-1208187 M5X8 SCREW HEX COUNTERSUNK	2
PC NO	PART NAME	QTY

1. Apply PVC Tape to the red marked areas
2. Thread in the automatic fasteners (3)
3. Slide in the cornerclips (2); note the 3mm gap

5	CWC-SP0008-P01_CAMSUPPORT SHORT	1
4	CWC-ST1003-P04_ITEM FRAME OUTSIDE LENGTH	1
3	NUTSTEIN M5 PROFIL 5 ITEM 0.0.425.11	5
2	BN616-1208187 M5X8 SCREW HEX COUNTERSUNK	5
1	CWC-SP0011-P01_CORNERCLIP FEMALE	2
PC NO	PART NAME	QTY

1. Apply PVC Tape to the red marked areas
2. Slide in the cornerclips (1); note the 23 mm gap
3. Attach the CAMsupport (5)

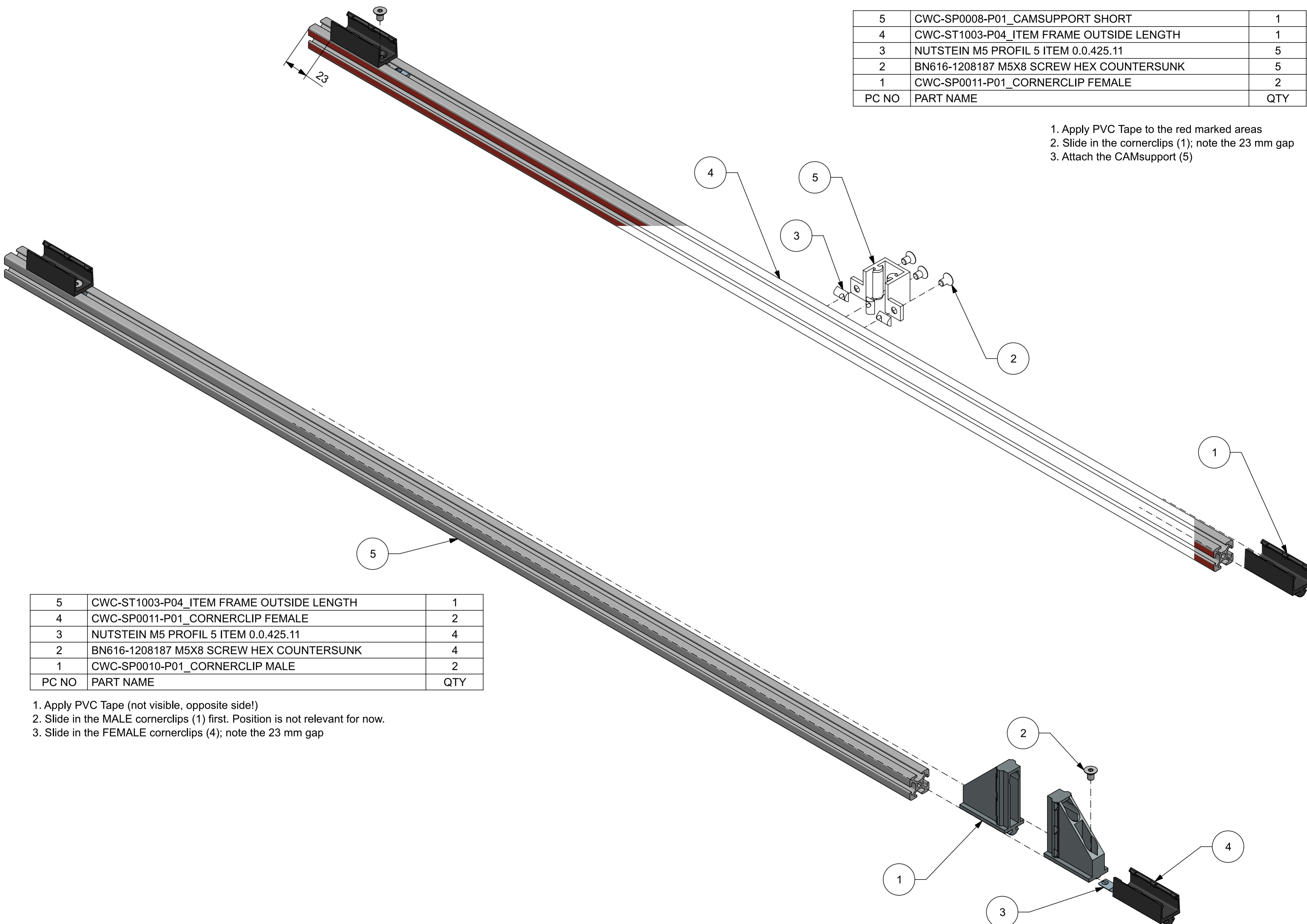

5	CWC-ST1003-P04_ITEM FRAME OUTSIDE LENGTH	1
4	CWC-SP0011-P01_CORNERCLIP FEMALE	2
3	NUTSTEIN M5 PROFIL 5 ITEM 0.0.425.11	4
2	BN616-1208187 M5X8 SCREW HEX COUNTERSUNK	4
1	CWC-SP0010-P01_CORNERCLIP MALE	2
PC NO	PART NAME	QTY

1. Apply PVC Tape (not visible, opposite side!)
2. Slide in the MALE cornerclips (1) first. Position is not relevant for now.
3. Slide in the FEMALE cornerclips (4); note the 23 mm gap

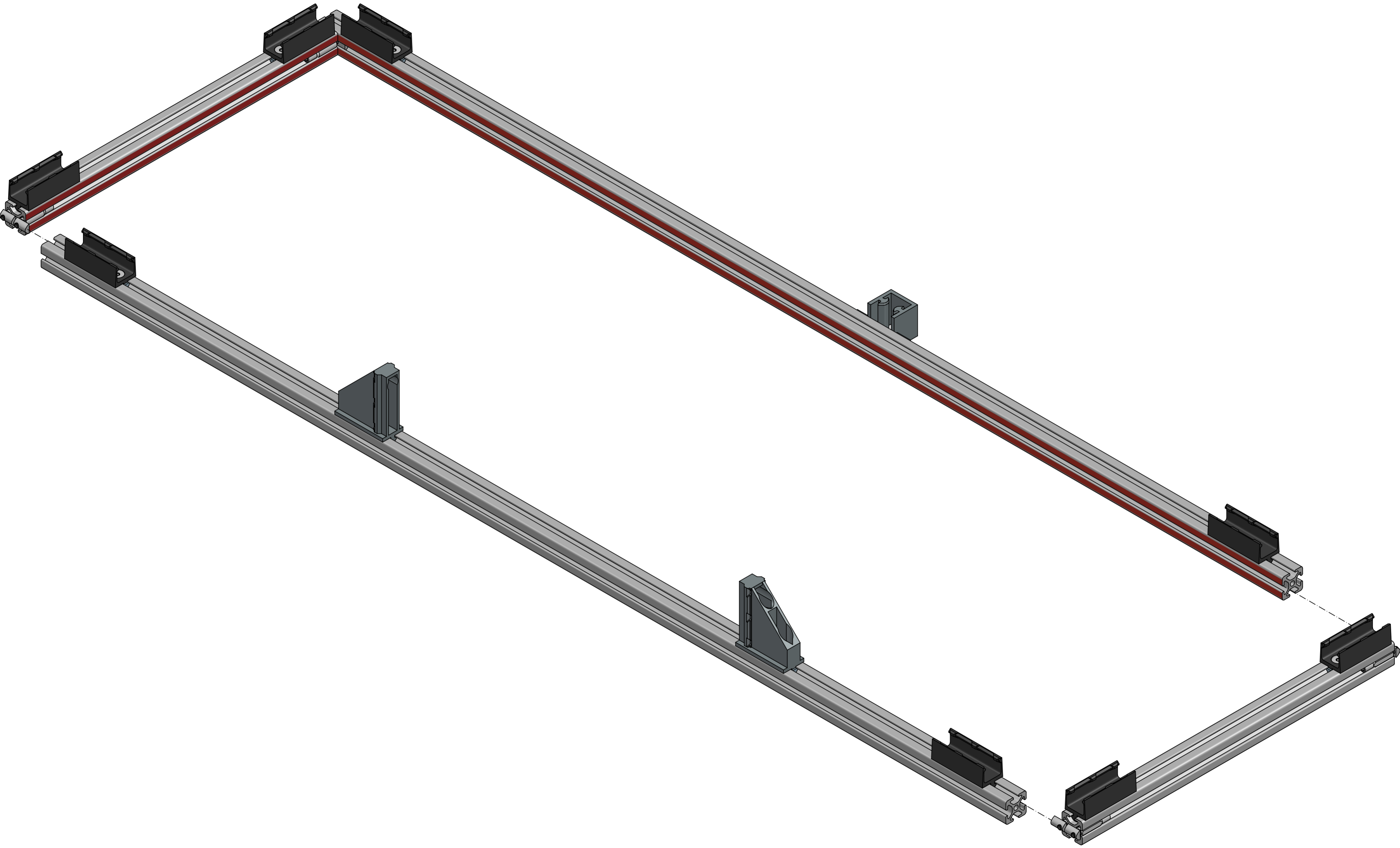

4x

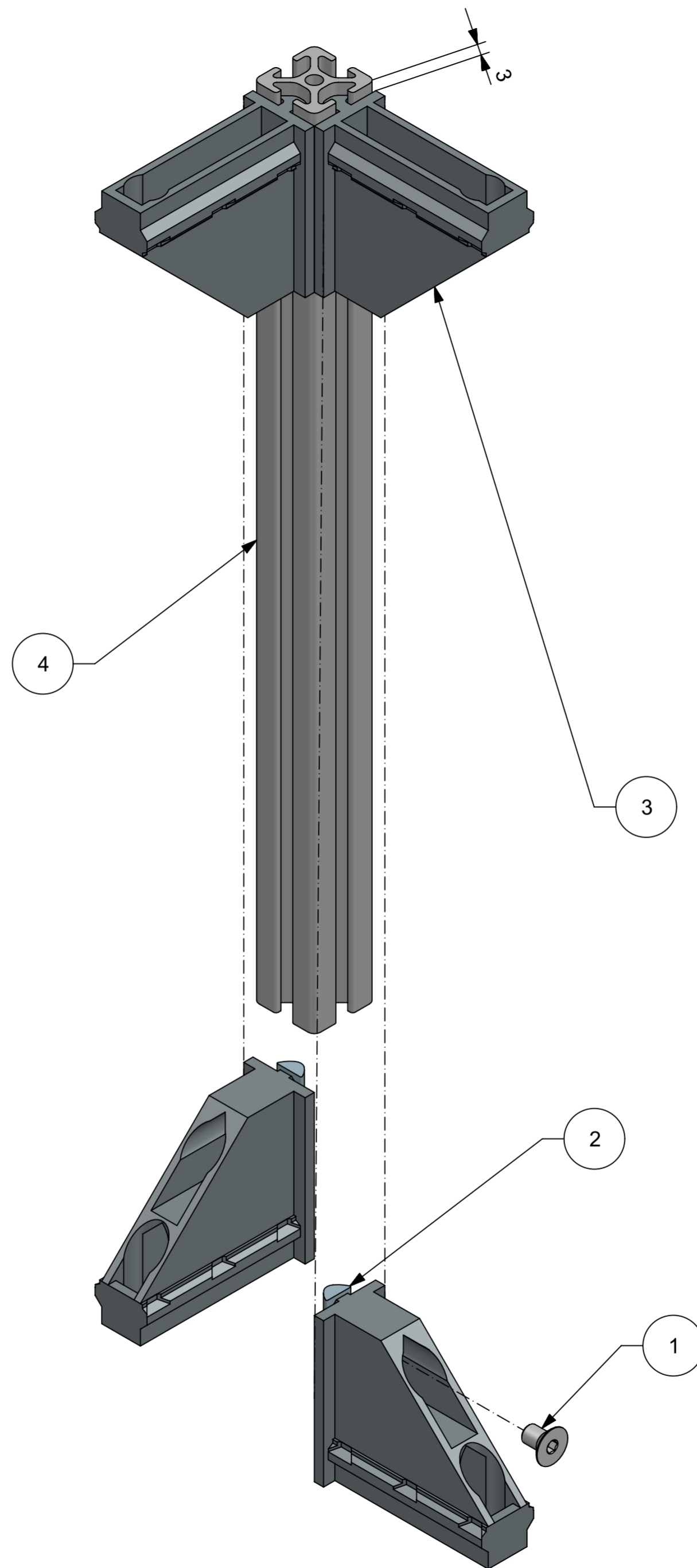

3. Slide in the cornerclips (3); note the 3mm gap

4	CWC-ST1005-P04_ITEM FRAME OUTSIDE HEIGHT	1
3	CWC-SP0010-P01_CORNERCLIP MALE	4
2	NUTSTEIN M5 PROFIL 5 ITEM 0.0.425.11	4
1	BN616-1208187 M5X8 SCREW HEX COUNTERSUNK	4
PC NO	PART NAME	QTY

4	CWC-ST1004-P04_ITEM FRAME OUTSIDE WIDTH	1
3	BN616-1208187 M5X8 SCREW HEX COUNTERSUNK	2
2	NUTSTEIN M5 PROFIL 5 ITEM 0.0.425.11	2
1	CWC-SP0011-P01_CORNERCLIP FEMALE	2
PC NO	PART NAME	QTY

1. Apply PVC Tape to the red marked areas
2. Slide in the cornerclips (1); note the 3mm gap

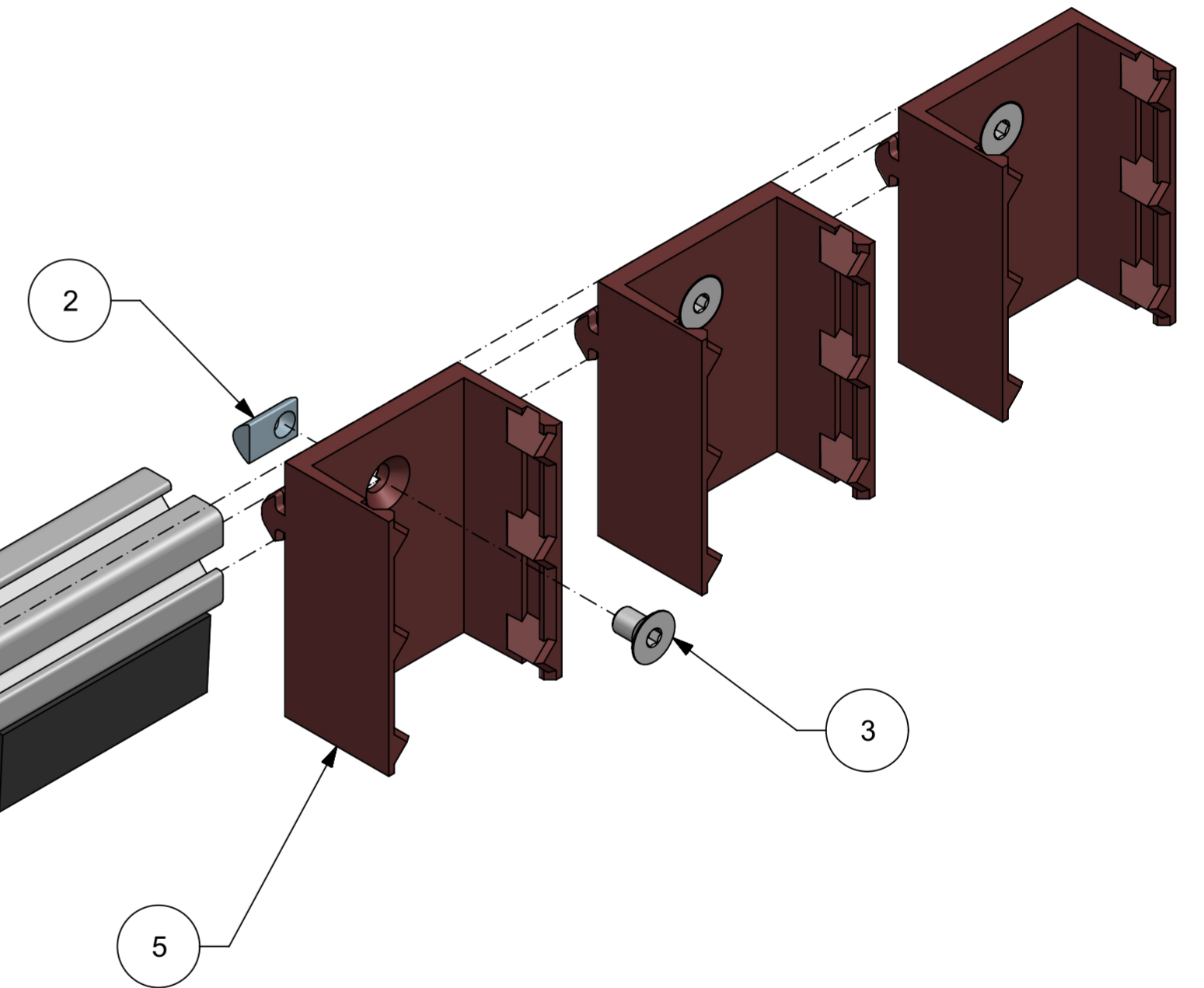
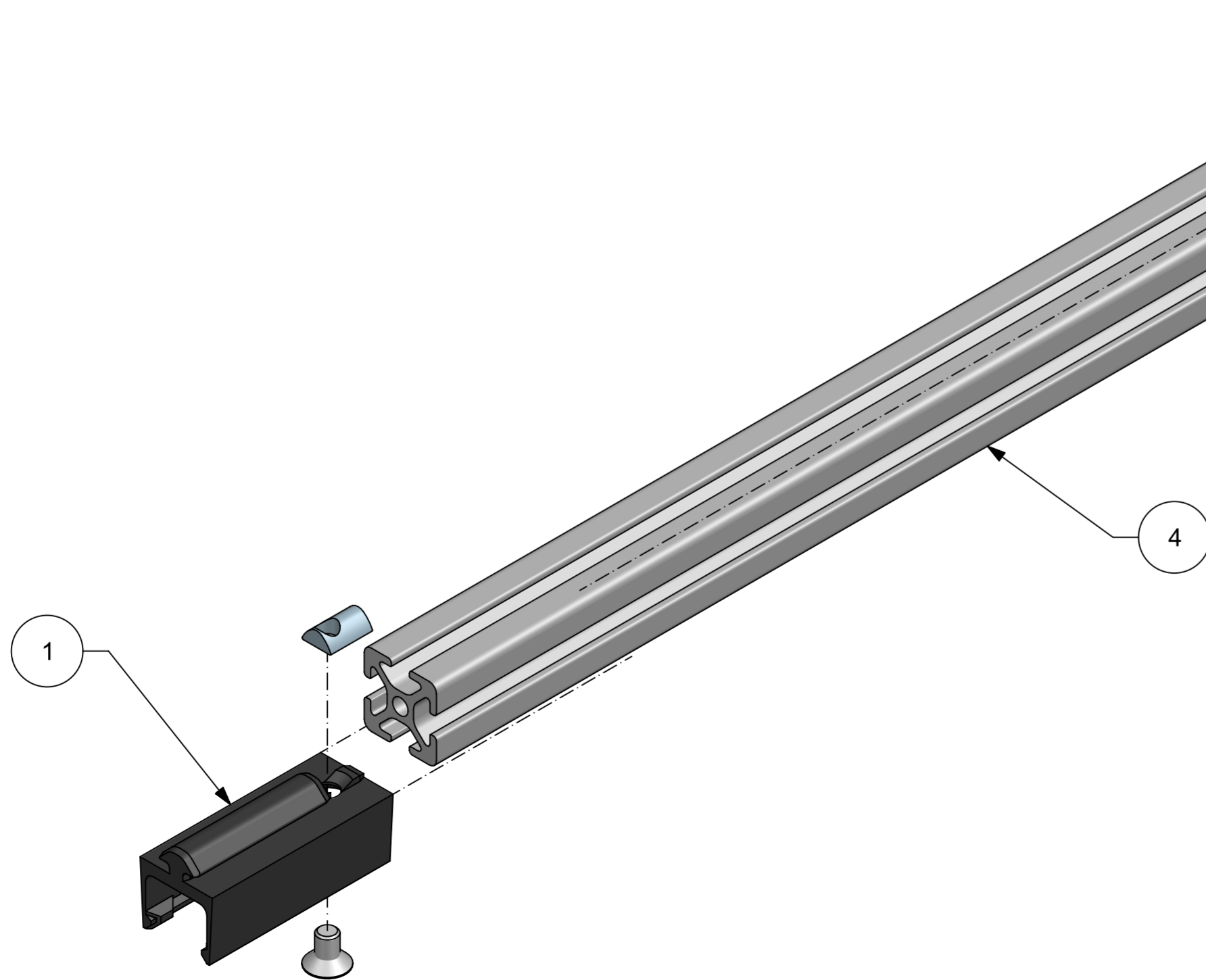
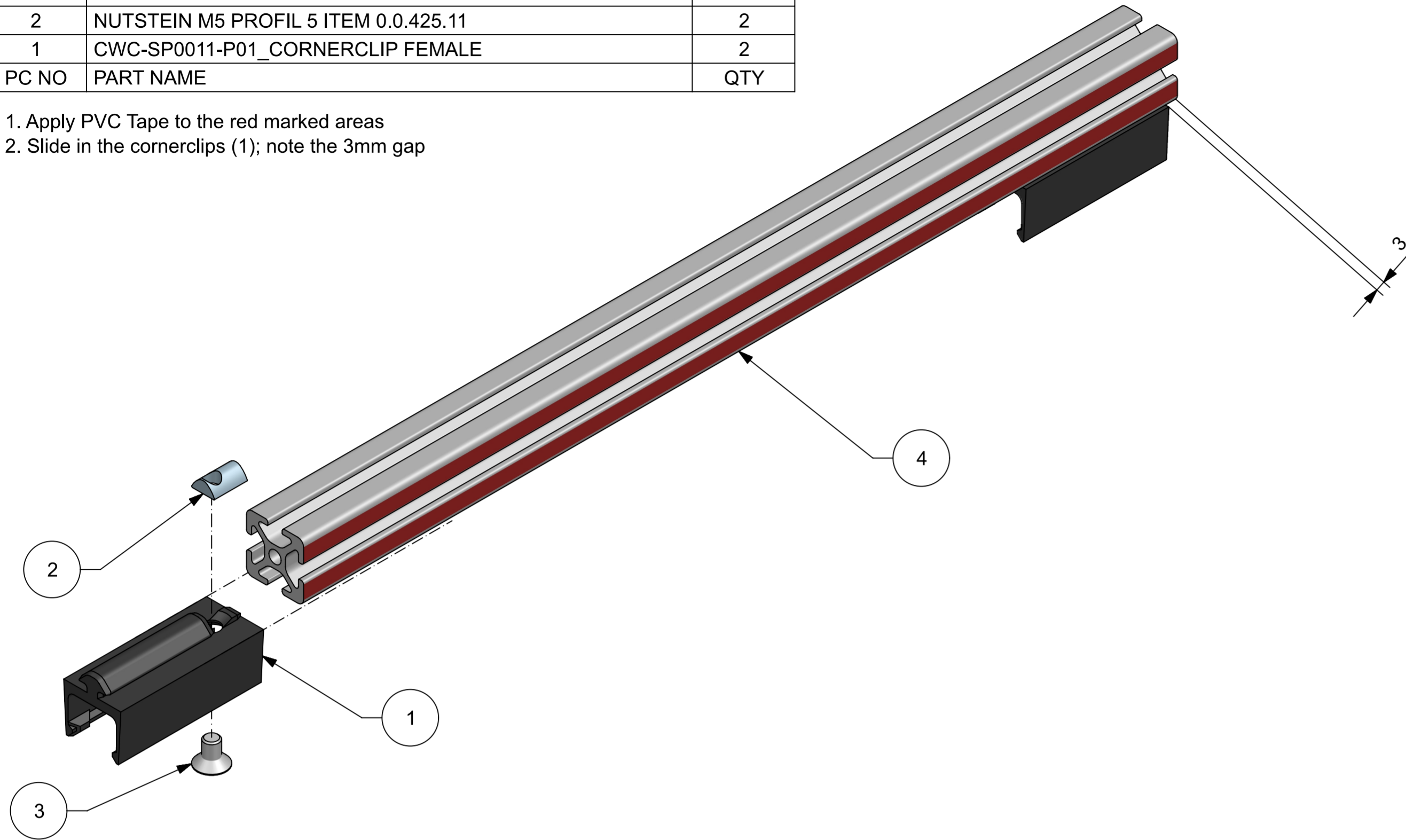

5	CWC-PR0001-P04_SNAP HOLDER	3
4	CWC-ST1004-P04_ITEM FRAME OUTSIDE WIDTH	1
3	BN616-1208187 M5X8 SCREW HEX COUNTERSUNK	5
2	NUTSTEIN M5 PROFIL 5 ITEM 0.0.425.11	5
1	CWC-SP0011-P01_CORNERCLIP FEMALE	2
PC NO	PART NAME	QTY

1. Apply PVC Tape (not visible, opposite side!)
2. Slide in the cornerclips (1); note the 3mm gap
3. Slide in the Snap Holders (5); space evenly

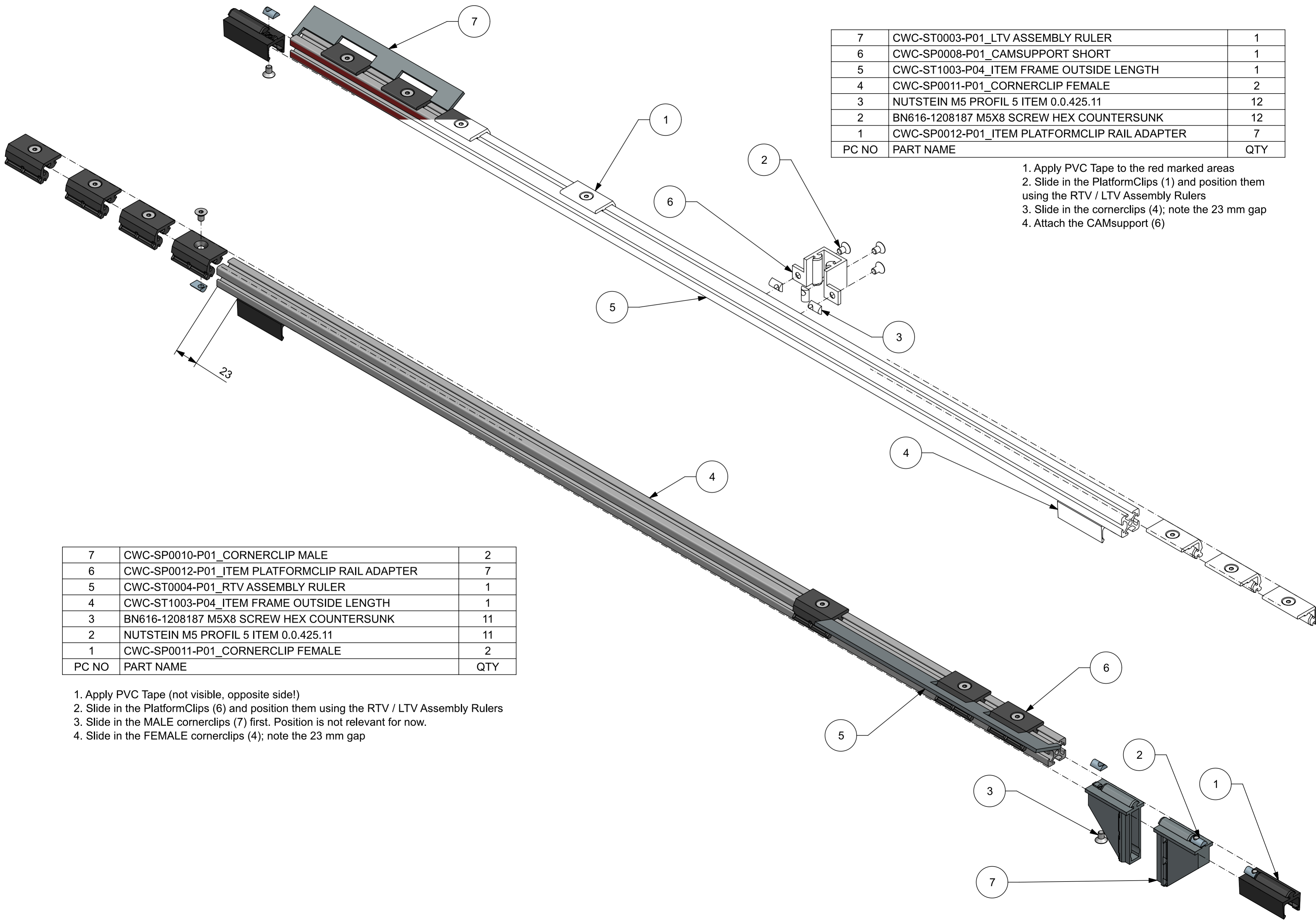

7	CWC-ST0003-P01_LTV ASSEMBLY RULER	1
6	CWC-SP0008-P01_CAMSUPPORT SHORT	1
5	CWC-ST1003-P04_ITEM FRAME OUTSIDE LENGTH	1
4	CWC-SP0011-P01_CORNERCLIP FEMALE	2
3	NUTSTEIN M5 PROFIL 5 ITEM 0.0.425.11	12
2	BN616-1208187 M5X8 SCREW HEX COUNTERSUNK	12
1	CWC-SP0012-P01_ITEM PLATFORMCLIP RAIL ADAPTER	7
PC NO	PART NAME	QTY

1. Apply PVC Tape to the red marked areas
2. Slide in the PlatformClips (1) and position them using the RTV / LTV Assembly Rulers
3. Slide in the cornerclips (4); note the 23 mm gap
4. Attach the CAMsupport (6)

7	CWC-SP0010-P01_CORNERCLIP MALE	2
6	CWC-SP0012-P01_ITEM PLATFORMCLIP RAIL ADAPTER	7
5	CWC-ST0004-P01_RTV ASSEMBLY RULER	1
4	CWC-ST1003-P04_ITEM FRAME OUTSIDE LENGTH	1
3	BN616-1208187 M5X8 SCREW HEX COUNTERSUNK	11
2	NUTSTEIN M5 PROFIL 5 ITEM 0.0.425.11	11
1	CWC-SP0011-P01_CORNERCLIP FEMALE	2
PC NO	PART NAME	QTY

1. Apply PVC Tape (not visible, opposite side!)
2. Slide in the PlatformClips (6) and position them using the RTV / LTV Assembly Rulers
3. Slide in the MALE cornerclips (7) first. Position is not relevant for now.
4. Slide in the FEMALE cornerclips (4); note the 23 mm gap

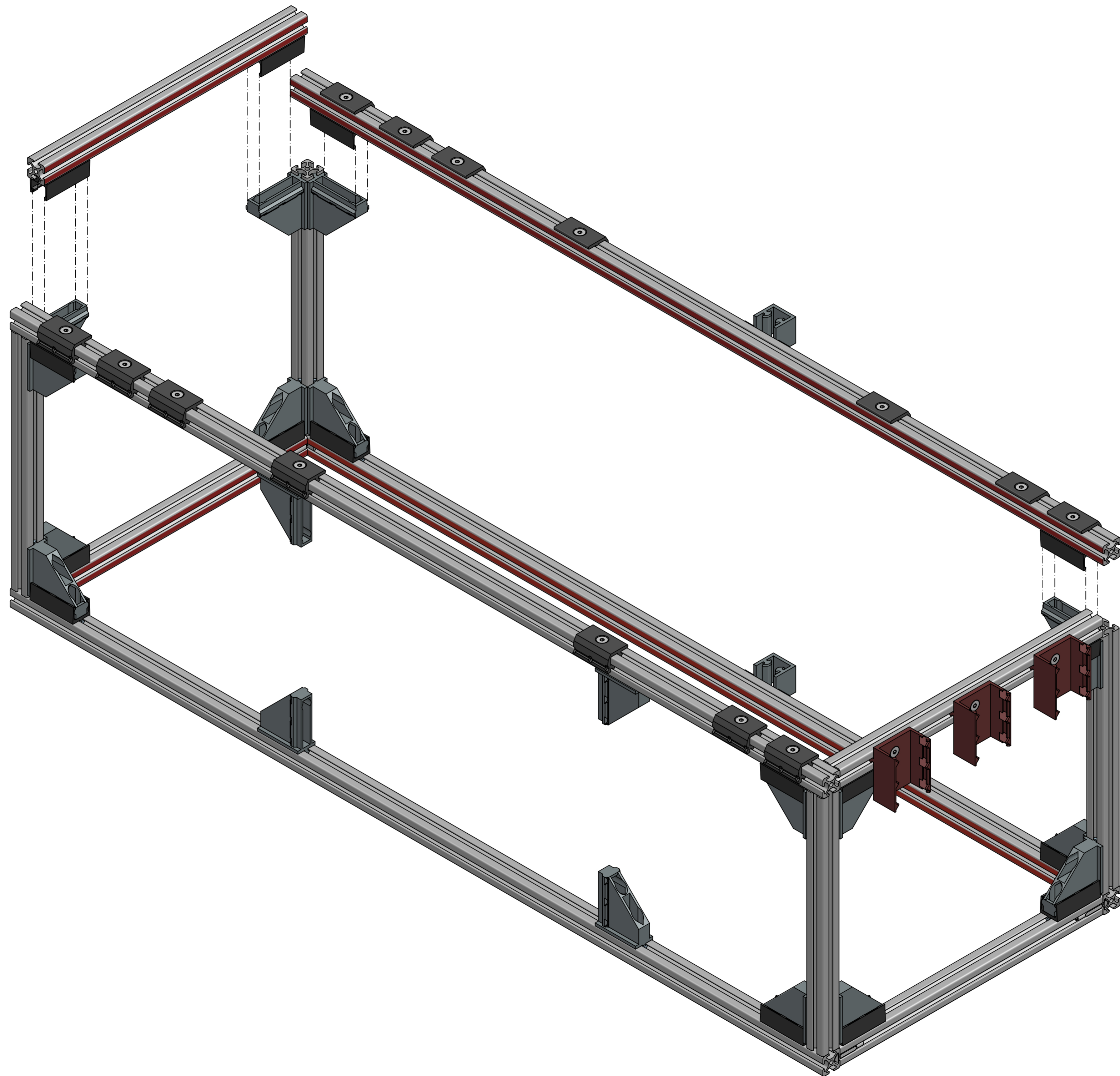

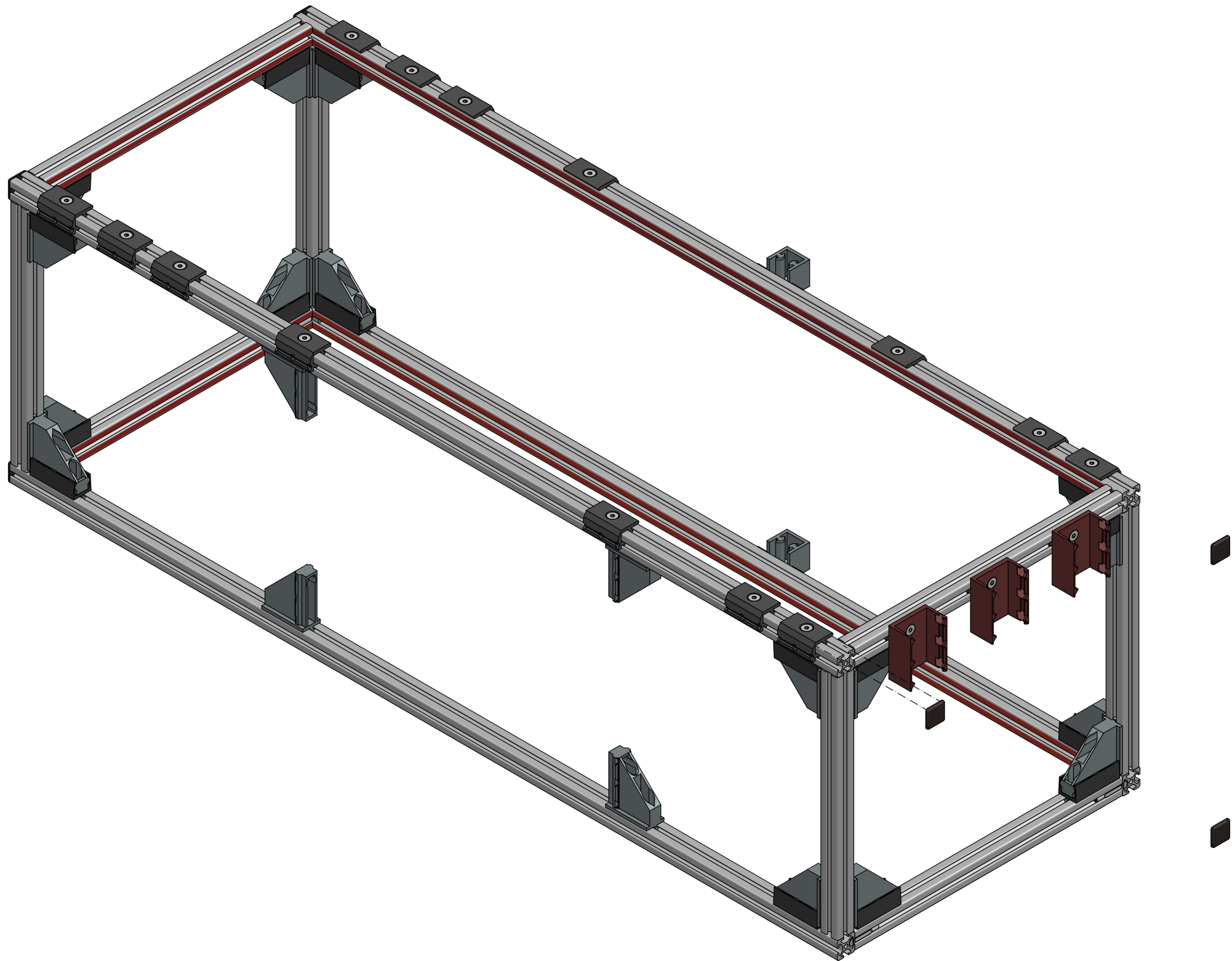

1	ABDECKKAPPE PROFIL 5 ITEM 0.0.370.09	8
PC NO	PART NAME	QTY

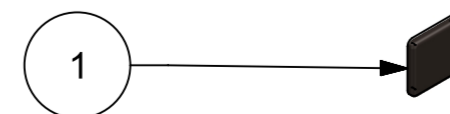

1

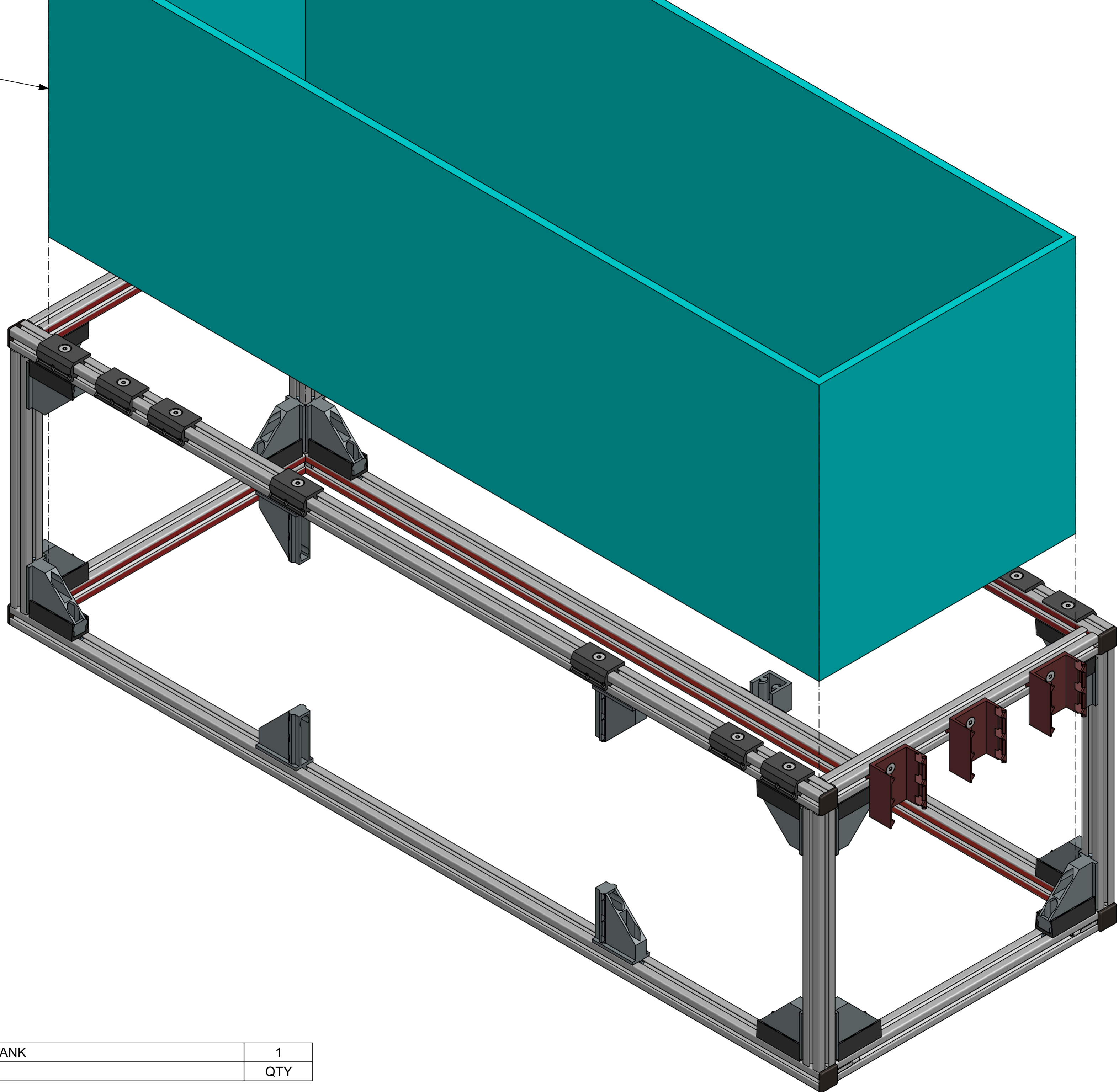

1	CWC-ST0003-P02_FISHTANK	1
PC NO	PART NAME	QTY